



**KUMERA  
GETRIEBE**

*Creating Efficiency*

Custom Made Gear Units  
Gearing Components  
Subcontract Work  
Repairs and Service  
Consultancy



**Kumera Getriebe GmbH**

53842 Troisdorf  
Germany

**Kumera**

## MILESTONES



### 1901

The Keller Mechanical Workshop was established and operation initiated in 50 m<sup>2</sup> location.



### 1917

Production of gear wheels and pinions was taken into the production in expanded workshop.



### 1936

Gearbox deliveries were expanded to many new industries, such as steel open pit minings.



### 1986

The deliveries of large dimensioned gearboxes were shipped to new industries, such as cement and dredging applications



### 2007

The company made extensive investments in its machine tools including extra large gear grinding machine.



### 2010

Further investments were made to reach the highest level of production in gearbox and components manufacturing.

### 2019

The operation of C.u.W. Keller GmbH & Co. KG was taken over by a subsidiary of Kumera Corporation, Kumera Getriebe GmbH to continue the long and successful tradition of the company as one of the greatest gearbox manufacturers of the world.



**KUMERA**  
CORPORATION

## KUMERA GETRIEBE FOR

MARINE

MINING

METALS

RUBBER AND PLASTIC

NUTRITION INDUSTRY

### INTRODUCTION TO KUMERA CORPORATION

Kumera Corporation is a private, family owned company, which consists of ten operating companies in four divisions, each in synergy with the other divisions adding value in the related value chain. These divisions are:

- 1 Kumera Technology Division,** the Process machinery supplier with affiliated mechanical workshop companies in Finland.
- 2 Kumera Power Transmissions** producing gearboxes and main related equipment to the pulp and paper, mining and metallurgical and dredging industries and to marine and offshore applications among others. The group has manufacturing plants in Finland, Austria, China, Germany and Norway.
- 3 Kumera Foundry Division** with a foundry in Finland being a major producer of steel and nodular iron castings supplying to engineering industries and Kumera's other divisions.

- 4 Kumera Marine Division** engineering, manufacturing and supplying propulsion gearboxes and propellers including control systems for any seafaring vessels and dredging equipment.

We are committed to the promise of "Creating Efficiency" for customers by maximizing the synergy between the related divisions. We trust that you find Kumera equipment and products applicable to your requirements and see the advantage in sharing the benefit of the "Creating Efficiency" and reduced environmental impact.

## EFFICIENT POWER TRANSMISSIONS

Dear Reader,

Kumera Getriebe GmbH a fully owned subsidiary of Kumera Corporation continues the long tradition of production in gear technology of Carl und Wilhelm Keller GmbH & Co. KG established in the year 1901.

The company has been developing its expertise close to none in many application sectors counted from open pit mining, ship building and dredging and in metals industries. The massive numbers of highly demanding projects carried out throughout the world laid basis for absolute reliable solution where heavy duty and heavy weight gearboxes up to 300 t and their related components are needed.

Kumera offers transmission solutions from a single source. We design, produce, repair, maintain and optimise with the highest know-how and long term experience in heavy duty individually manufacture custom-made gearboxes.

Due to the most modern methods in gear technology and in its realization with state of the art machineries and testing facilities, Kumera offers also highest quality standards known in the industry. We always work quickly and with absolute precision. This this is how we can guarantee our customers an optimum price-performance ratio.

- Our portfolio includes the design and manufacture of gear wheels with diameters of up to 4.0 m and, based on these, the development and production of innovative transmission units weighing up to 300 tonnes.
- We transmit power in many industries where heavy duty and heavy weight power transmissions units are in operation. Our most heaviest unit weighs 300 tonnes. Examples are in the cement, sugar, steel, plastics, opencast mining, shipbuilding and chemicals industries, as well as in different kinds of power plants.
- For all these sectors, we produce unique gearing components. Kumera has large operation for maintenance and upgrading existing gearboxes independent on their original makers. The service operation is 24/7 basis and supported by our Competent Service Centers in Austria, Nordic countries, China, Chile, and around of other industrialized continents.

In our service portfolio our gearing and drive experts are also available for consulting the most optimum drive solutions, which are beyond of our customers' core knowledge.

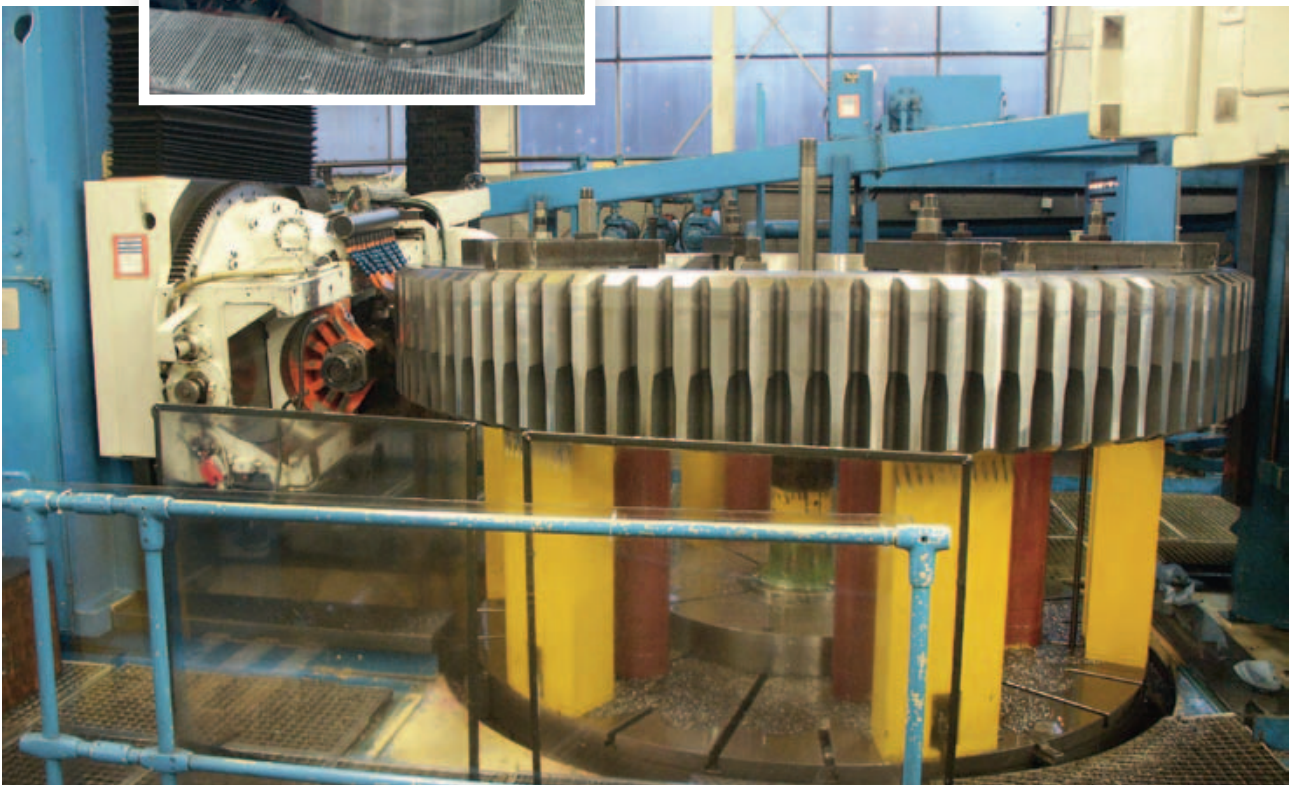
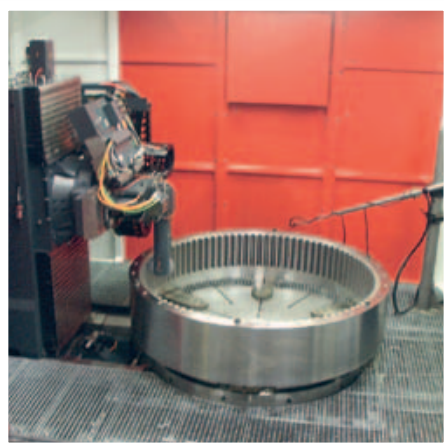

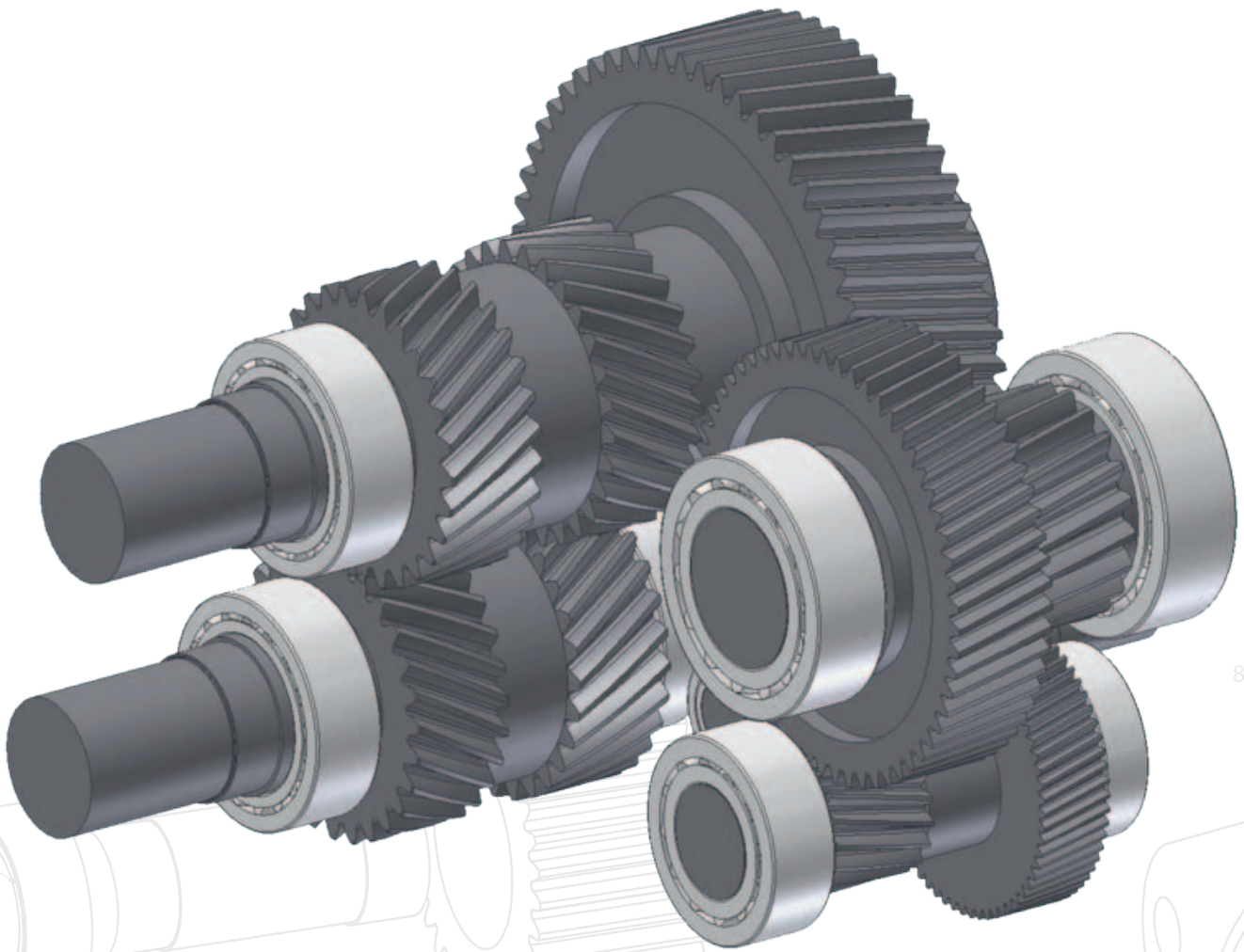

## OUR COMPETENCE ENSURES SUCCESSFUL OPERATION

The individual design and manufacture of custom-made gearboxes and gearing components are our core business. With engineering department, we offer new gear units, but also the possibility of calculating and designing gearing components by the most advanced methods for optimised performance. As a result of many years of membership of the German Research Association for Drive Technology (FVA), we also have the latest calculation methods for designing of gear units and gearing components so we are positioned ourselves for professional consultancy in any questions of gearing and drive systems.

- State of the art 3D and 2D CAD systems
- Calculation of all components (bearings, shafts, connecting elements etc.) according to current standards and regulations, using the latest programmes
- Design and recalculation of gearing in accordance with a wide range of standards, regulations and classification societies, e.g. according to DIN3990, ISO6336, AGMA, BS, Henriot, ABS, BV, GL etc. with the most advanced programmes such as FVA-STplus
- Calculation of tooth engagement load distribution with FVA-RIKOR and Plancor
- Efficiency and heat balance calculations
- Dynamic simulation
- FEM calculation
- Transmission related hydraulics and electrical systems

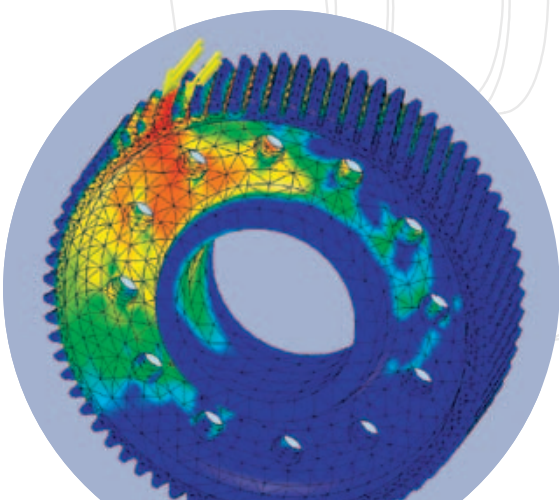

# KUMERA – CREATING EFFICIENCY

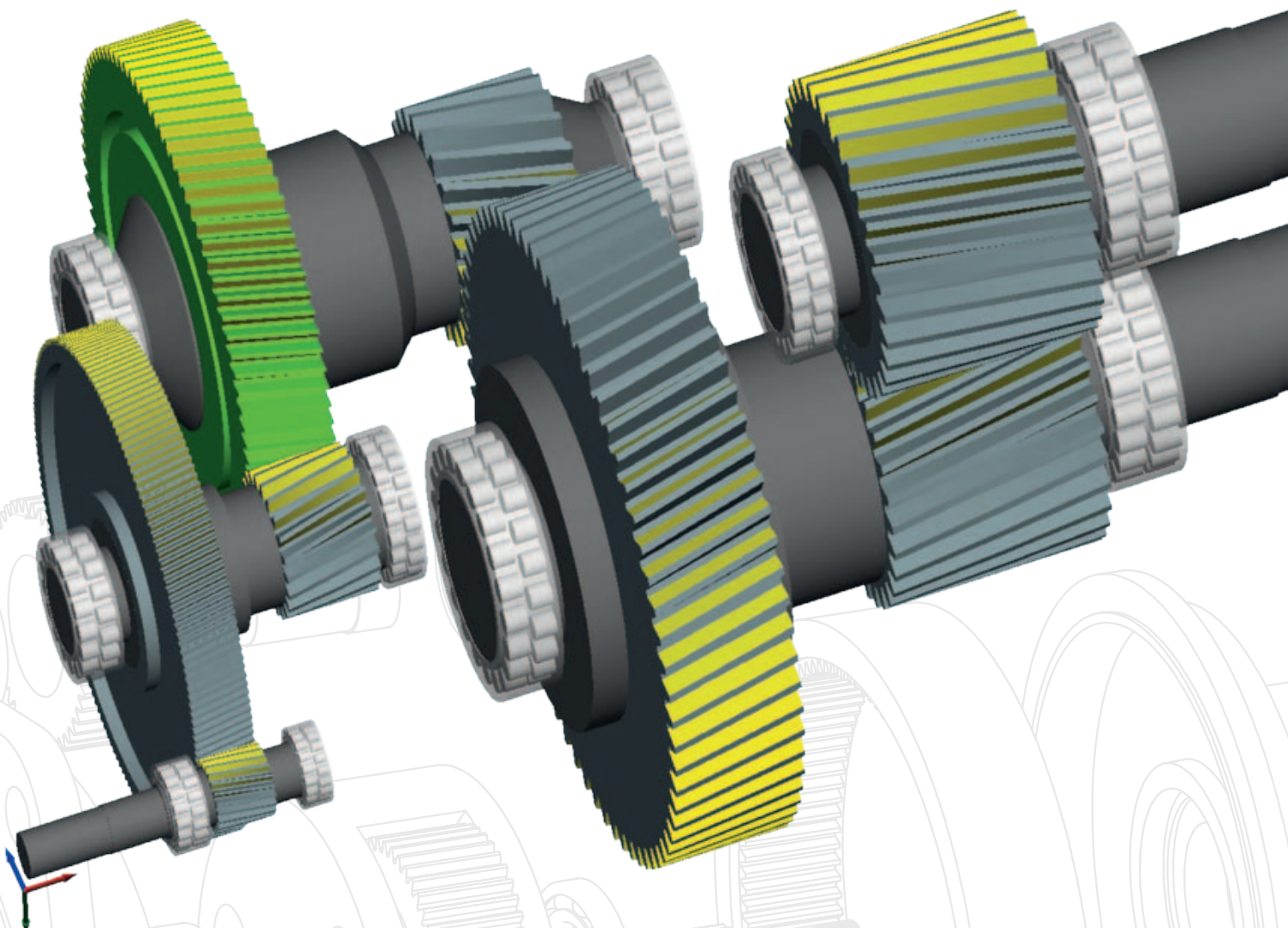

## CAREFULLY OPTIMIZED LOADS IN POWERTRAINS

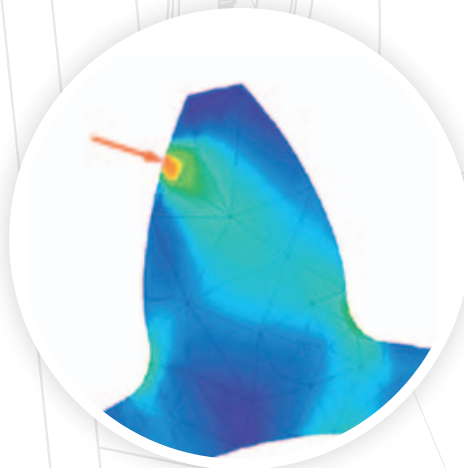

# KUMERA

*Creating Efficiency*

**Due to the long traditions in power transmissions technology and continuously increasing demand of our gearings, the existing product line covers wide range of heavy duty and heavy weight gearboxes for many applications in different industries.**

**SHIPPING**

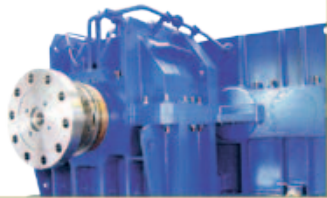

**STEEL INDUSTRY**



**OPENCAST MINING**

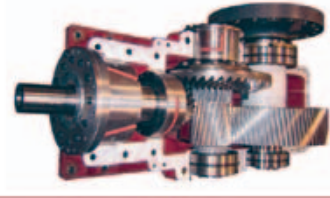

**FOOD INDUSTRY**



**RUBBER & PLASTICS INDUSTRY**



**CEMENT INDUSTRY**



**POWER**



**CHEMICALS & REFINERIES**



**CRANE GEARBOXES**



## KUMERA MARINE APPLICATIONS

In maritime operation – especially in the dredging and offshore sector - gearboxes demonstrate their high quality on deck and in the engine room: from propeller transmissions with an output of 15,000 kW and more to dredge pumps, jet pumps, winch, generator and transfer case transmission units and special cutter head and cutter wheel gear units.



Kumera offers complete propulsion system, where the subsidiary of Kumera Corporation, Helseth AS, Norway is the propeller supplier.

### Propellers

- Propeller design optimized to vessel requirements and operational profile
- Engine power up to 4500 kW
- Propeller diameter up to 4500 mm
- Open and nozzle propellers
- 3- and 4-bladed



## Propellers by Helseth AS

Application – Conventional Vessels



**CARGO  
VESSEL**

**AQUACULTURE  
SERVICE VESSEL**

**LIVE FISH  
CARRIER**

**FISHING  
VESSEL**



## KUMERA GEAR UNITS FOR STEEL AND ALUMINIUM INDUSTRY

Kumera know-how has been power transmitting factor in the iron and steel industry for over a hundred years. Our gear units are in use all over the world. The wide range of products covers gear units in the medium and large ranges. Among other things, we produce pinion stand gearboxes, coiler gears, scissor drives, leveler gearboxes, draw bench drives and sendzimir gear units. With single or double helical gearing and gearing components according to individual specifications. Kumera designs and produces the drive units for the manufacture for steel and aluminium industries.

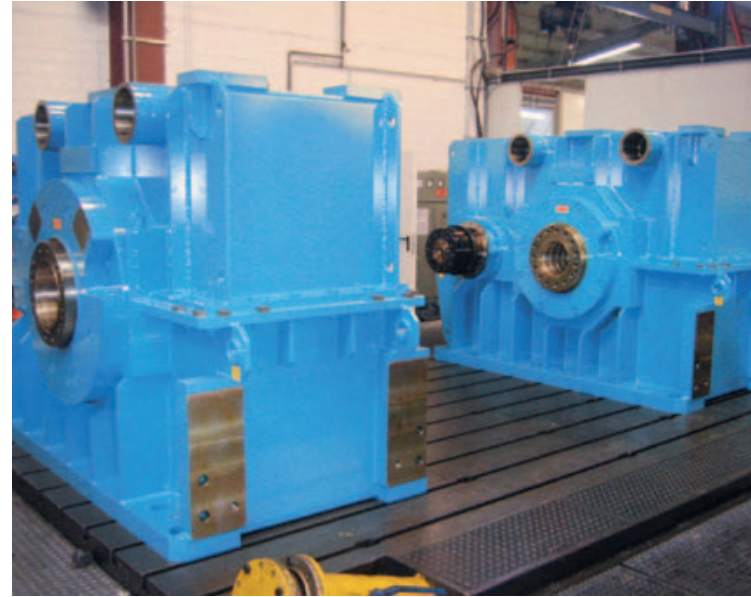
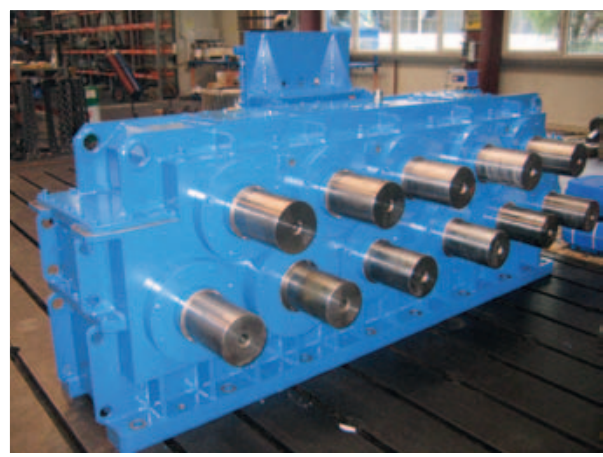



## GEAR UNITS FOR OPEN PIT MINING AND MAINTENANCE SERVICE

Particularly in the open pit mining, we combine our ongoing experience with new scientific knowledge. This is the basis on which we develop gear units with a drive power of 2,500 kW and more, setting new standards for sealing and lubrication concepts.

These conditions set requirements for robust design and low maintenance, which the high-quality staff takes as a challenge covering motor applications in belt, bucket wheel, propulsion or traversing gear units and in generator operation.



## TRADITIONAL AND SAFE SUPPLIER FOR FOOD INDUSTRY

Kumera gearboxes for sugarbeet pulp presses are recognized for their extremely high torque. This is why they are in operation in nearly all the sugar processing plants worldwide. In other sections of the food industry too, over the decades, working with operators and universities, we have achieved a technological lead in the market. Naturally, we also offer the overhaul and upgrade of your existing gear units in this sector.

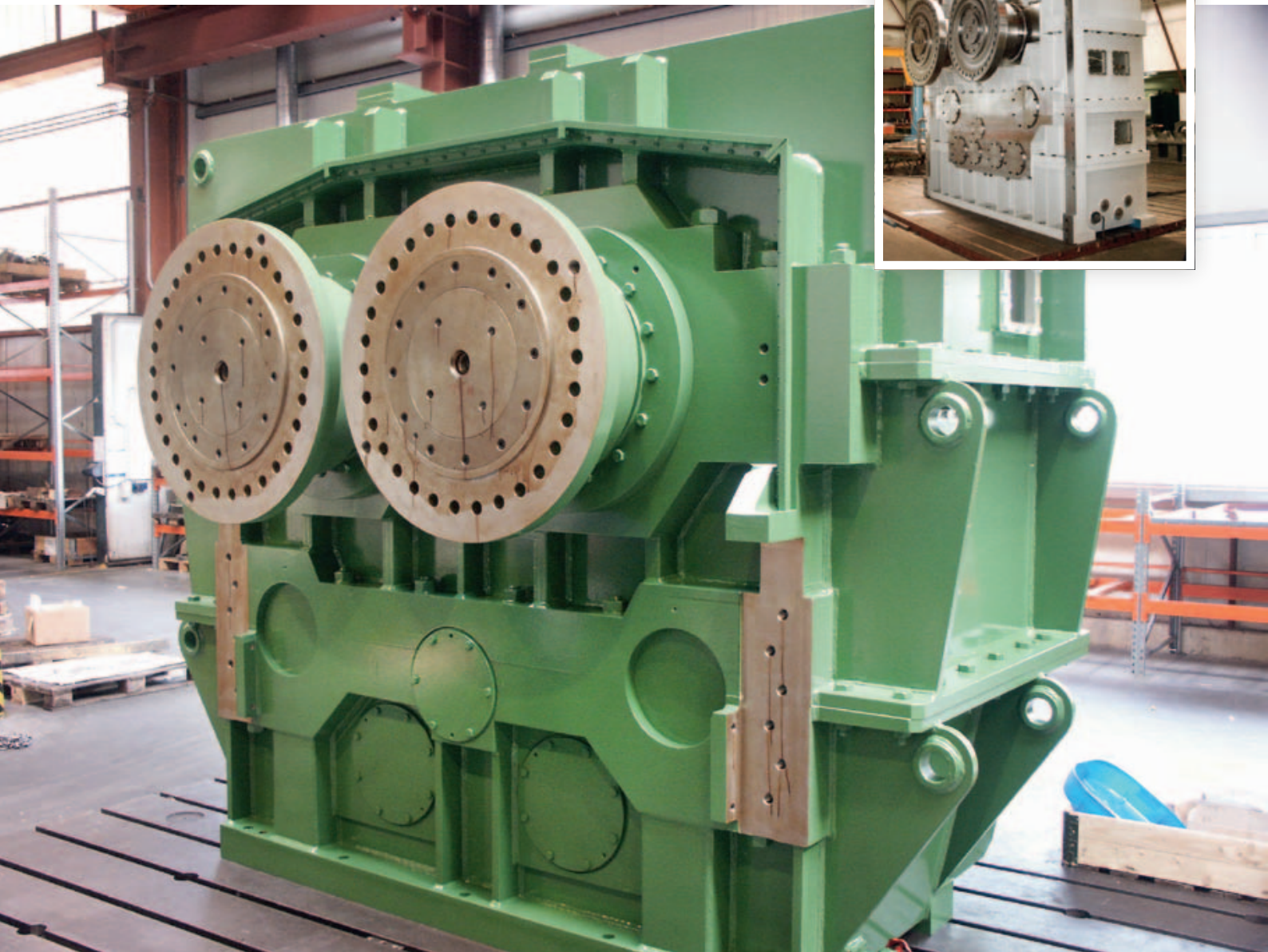
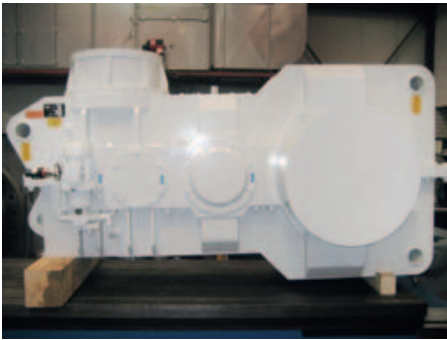

## KUMERA GEARBOXES FOR RUBBER AND PLASTICS INDUSTRIES TO SECURE PROPER ADHESION PROCESS

During many decades Kumera has been producing calender, extruder and rubber kneading gear units to meet the strictest requirements for the rubber and plastics industry. We work for well-known plant constructors and tyre manufacturers world wide.

We repair, overhaul and optimise gear units, including those from other manufacturers. In this way, we ensure smooth running and good adhesion.

There are gearboxes for continuous mixer which is featured with oscillating shaft movement. Our after sales service includes regular maintenance and overhauling measures, see Kumera Service on separate leaflet of the program.

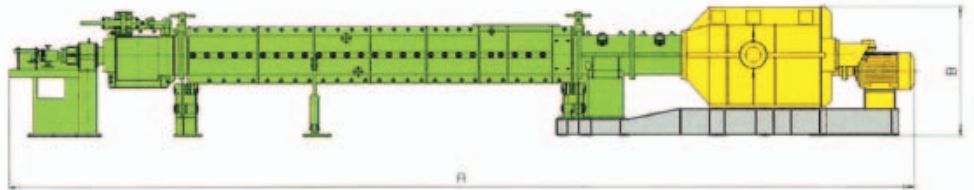

*Complete continuous mixer/kneader with oscillating gearbox.*

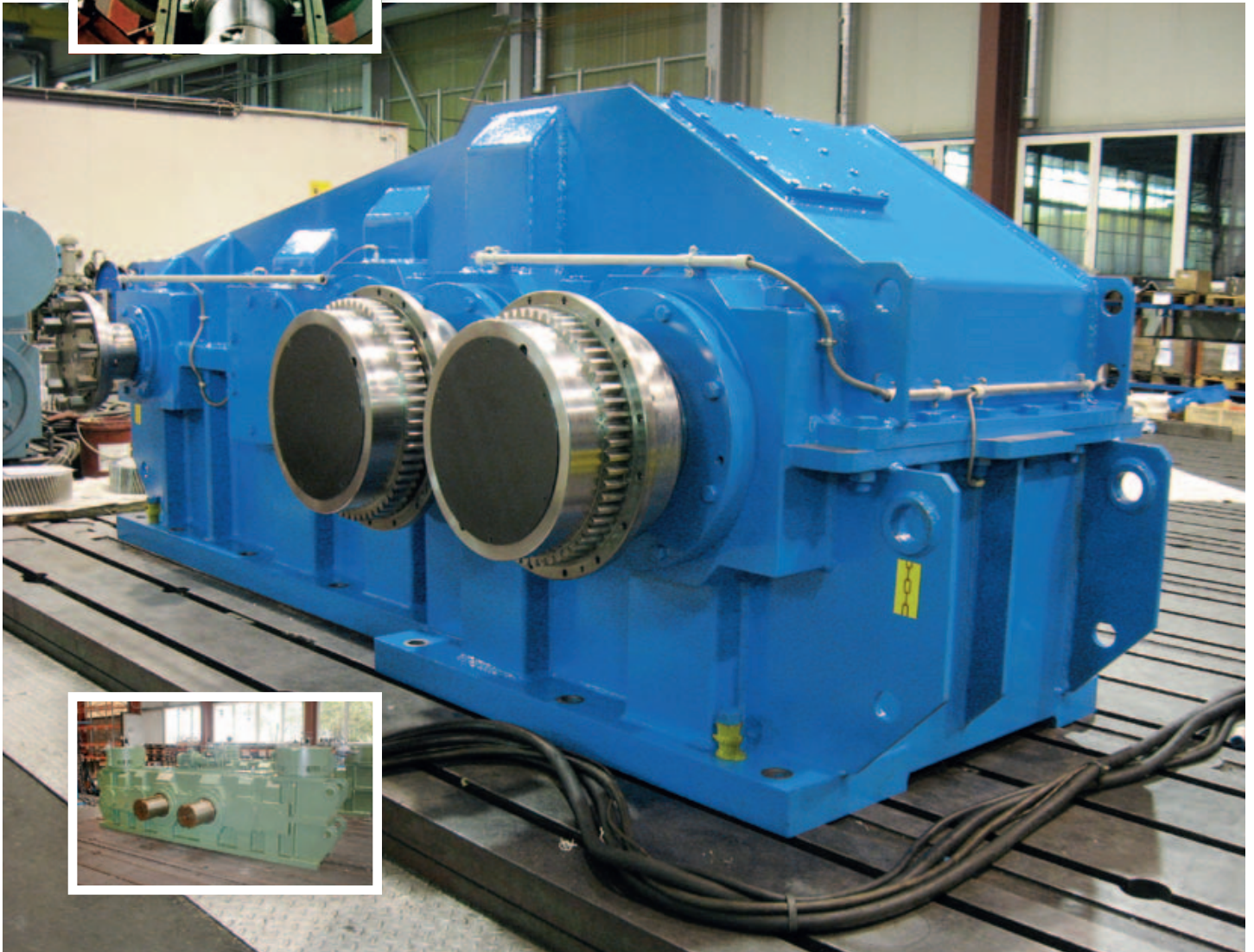

## KUMERA GEAR UNITS FOR CEMENT INDUSTRY

For the cement industry, we manufacture gear units for a wide range of applications, such as vertical and horizontal mill, kiln and belt transmissions. We also supply separate parts, including the drive pinions on the crown gears of mills and kilns, also in a case-hardened version.

In cement industry Kumera Gearboxes for kiln drives, vertical and horizontal mills and belt transmissions we delivery complete drive systems including girth gears and supporting rollers.



*Housings of cement mill gearboxes.*

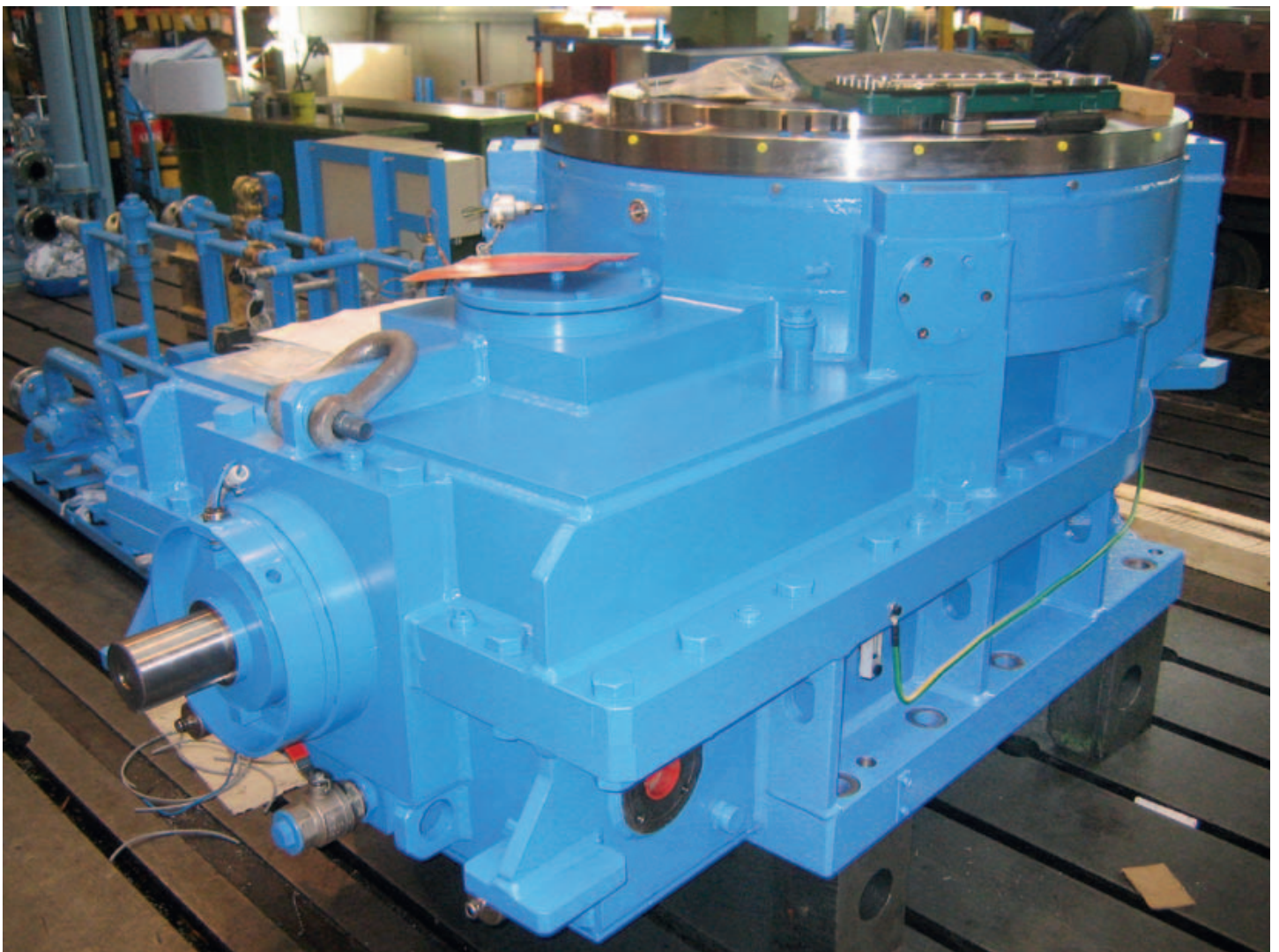

## KUMERA GEAR UNITS FOR POWER GENERATION – INNOVATIVE SOLUTIONS

There are many applications where Kumera has innovative power transmissions solutions within coal and peat fired power plants and turbine gearboxes for hydro power plants.

The large number of conveyor gearboxes belong to our material handling sector but are all of these power plants.

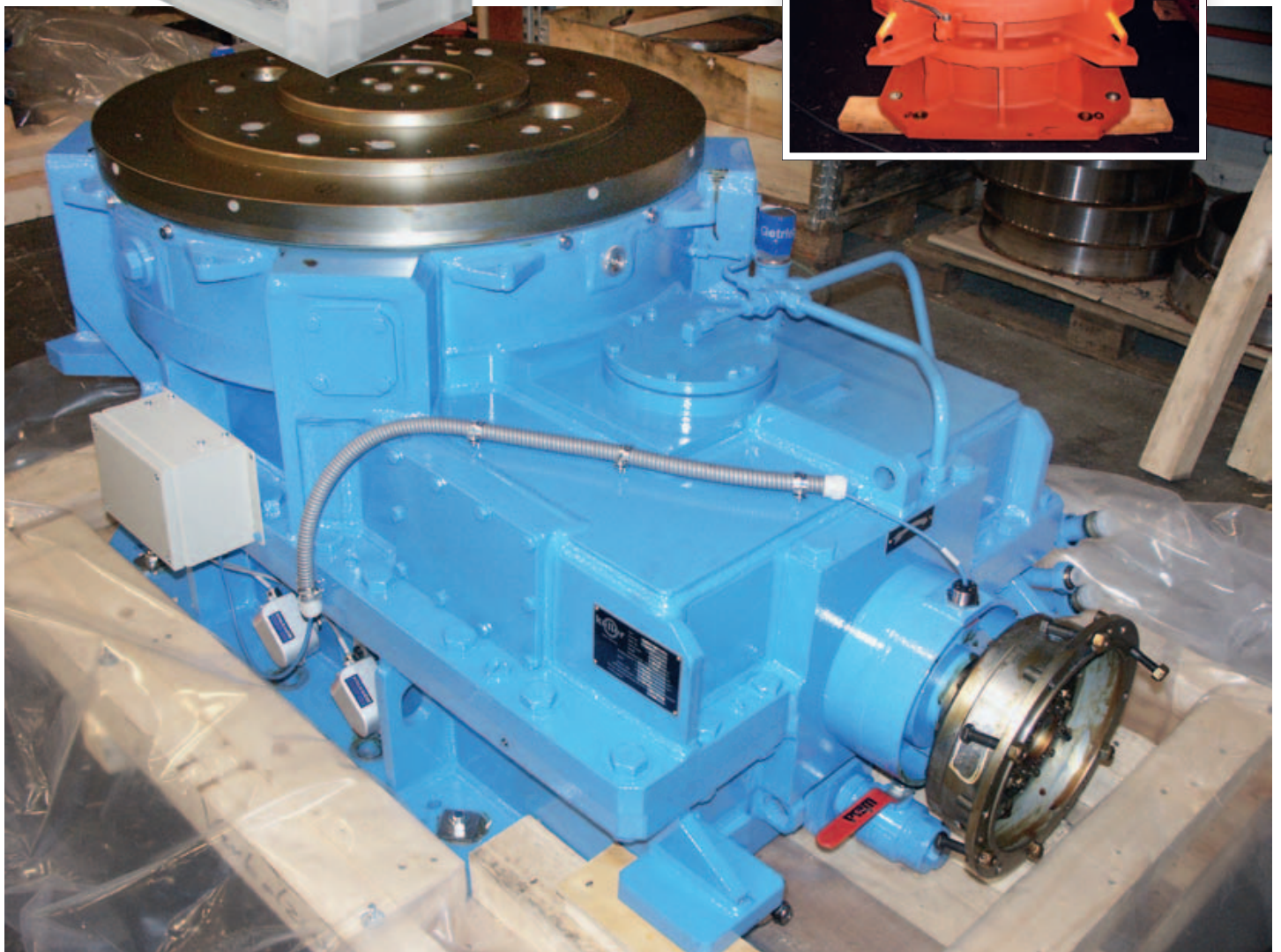

## KUMERA GEARBOXES FOR CHEMICAL INDUSTRY

Kumera offers wide range of mixer and agitator gearboxes developed throughout many decades. Addition to mixing Kumera has solutions for grinding, stirring, drying and for extrusion gearboxes.

Practically Kumera covers all needs in mechanical power transmissions within chemical industry and what the most important – accurately functioning maintenance and service function.

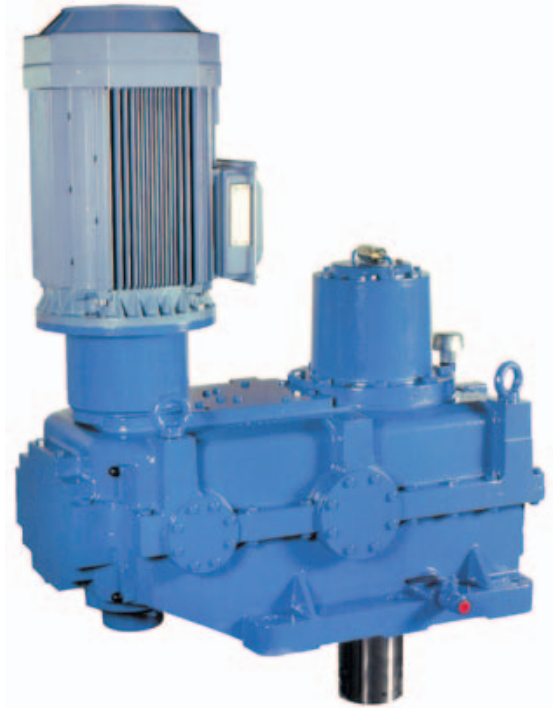

## BENEFICIAL EXPERTISE FOR CRANES

Kumera transmission solutions for lifting, slewing and travel gears in docks, steel and power plants to handle containers, casting operations or crab cranes. All are within our supply program.

Our wide experience and thorough expertise in gearing technology enable us to propose optimum solutions for crane applications and related material handling tasks.

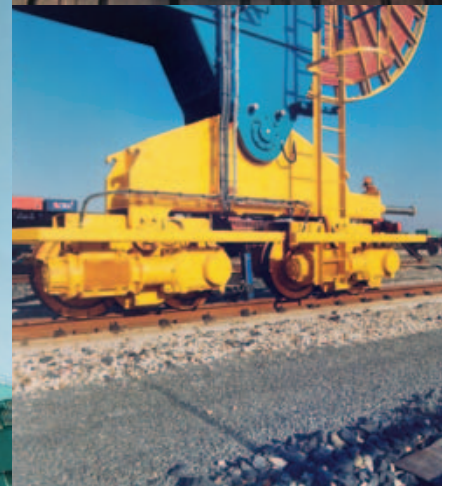
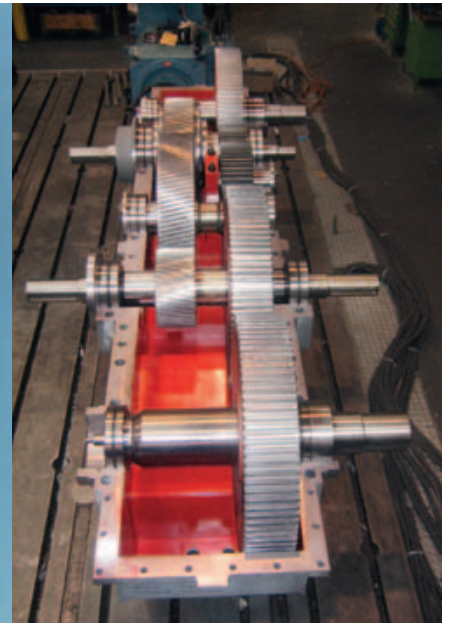
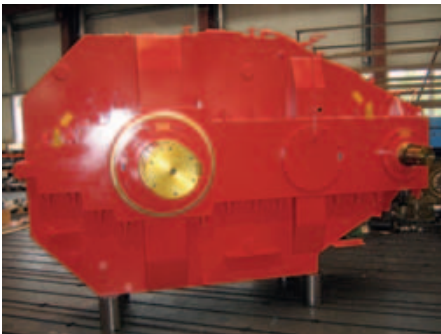

# PREVENTING FAILURES BY CONDITION MONITORING



## INSPECTION BY KUMERA: To keep gear unit moving

A systematic and regular inspection of the gearing and/or gear unit can avoid damage. So have your gear unit inspected by specialists.

### INSPECTION

- of the gear unit
- of the bearings
- of the gearing
- of the alignment of the gear unit with the coupling and the motor



## Revamping “old” gearboxes

Whether a repair or a new production, all working procedures are subject to the same quality requirements.

### WE DISTINGUISH BETWEEN 3 REPAIR LEVELS

- Reverse engineering: Restoration of original condition, e.g. with preliminary damage assessment
- Repair according to drawing: Use of modern bearings and gearing materials if necessary
- Repair with engineering: Upgrade and performance increase of up to 50%

## THE “COMPLETE TROUBLE-FREE PACKAGE” Condition Monitoring

### CONDITION MONITORING FOR YOUR GEAR UNIT

- threats of damage are detected in good time
- early warning helps to avoid or limit damage

## Health Monitoring



Power-Plaza - Health Portal  
• Online Dashboards

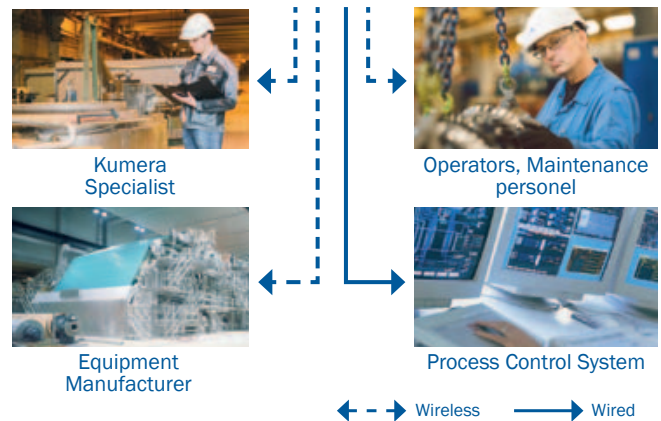



# UPGRADE AND UPDATE IN MAINTENANCE SERVICE

**An example:**

In 2008, an Austrian steelwork approached us with a special assignment: The gear units of an existing rolling mill had to be renewed and also made capable of handling modern, high tensile steel qualities. An order for new gear units was out of the question for cost reasons, as was a prolonged closedown of the plant.

**TYPICAL KUMERA:**

The existing gear units were redesigned by our engineering department within the narrow constraints of the system. The output was increased from 1150 kNm to 1350 kNm.

The parts were delivered to the customer in preassembled packages which just needed to be installed locally in the existing plant. The time taken for the refitting was one week.

An achievement which also had to comply with the following framework conditions:

- increased safety margins
- rebuilding, making use of existing spare parts
- maintenance of the moments of inertia in the otherwise identical drive train in order to avoid vibrations
- continued use of the transmission housing after local reconditioning

## Comparison of gearing safety factors before and after revamping

Number of teeth		Module	Material/ Heat treatment		Load-bearing capacity according to DIN 3990 (12.87); Method C P=2786.7 kW; n <sub>1</sub> =738 min <sup>-1</sup> ; K <sub>A</sub> =1.0			
			Old	New	Pitting safety S <sub>H</sub>		Tooth root safety S <sub>F</sub>	
					Old	New	Old	New
t1	25	12	30CrNiMo8V annealed	18CrNiMo7-6 case hardened	1.18	2.79	3.31	5.15
t2	165	12	30CrNiMo8V annealed	18CrNiMo7-6 case hardened	1.18	2.79	2.89	5.20
t3	43	16	30CrNiMo8V annealed	18CrNiMo7-6 case hardened	1.12	2.63	2.07	3.19
t4	159	16	42CrMo4V annealed	18CrNiMo7-6 case hardened	1.05	2.68	1.75	2.95

**BEFORE**



**AFTERWARDS**



## GEARING COMPONENTS FOR MACHINERY – ONE MESHES PERFECTLY WITH THE OTHER



Gearing optimization has convinced many users of Kumera gearboxes and drive systems. There are several innovations in question, f.e. case hardened welded helical gearwheels in large diameters by 1.5 meter. This innovation has resulted major reduction in the weight of a gearwheel and correspondently in costs.

### Large gear cutting facilities:

- roll milling
- gear shaping
- profile gear flank grinding
- generating gear flank grinding
- 6-axis free form milling (hard and soft milling)
- profile drawing

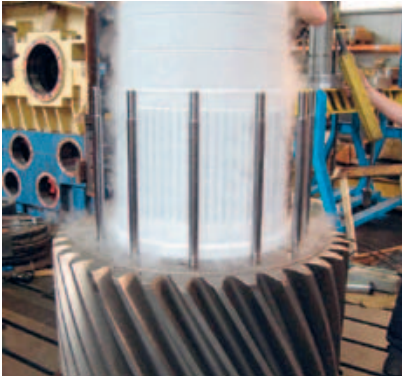

## KUMERA – HOUSE OF QUALITY

**The quality of our products has the highest priority, so we work with state of the art test equipment and measurement methods, including:**

- ULTRASONIC TESTING, for the detection of faults in the material
- SOUND LEVEL MEASUREMENT, to determine the noise emission of gear units
- SURFACE CRACK EXAMINATION, for the detection of cracks in the surface of the material
- VIBRATION MEASUREMENT, for the detection of gear unit defects and disturbances while it is running
- LASER MEASUREMENT, for the precise alignment of gear unit, coupling and motor
- TORQUE MEASUREMENT, mobile local testing and analysis of torque curves on gear and drive units
- GEAR TESTING MACHINES, to determine the quality of the involutes, the flank line, the pitch and the concentricity of the gears.

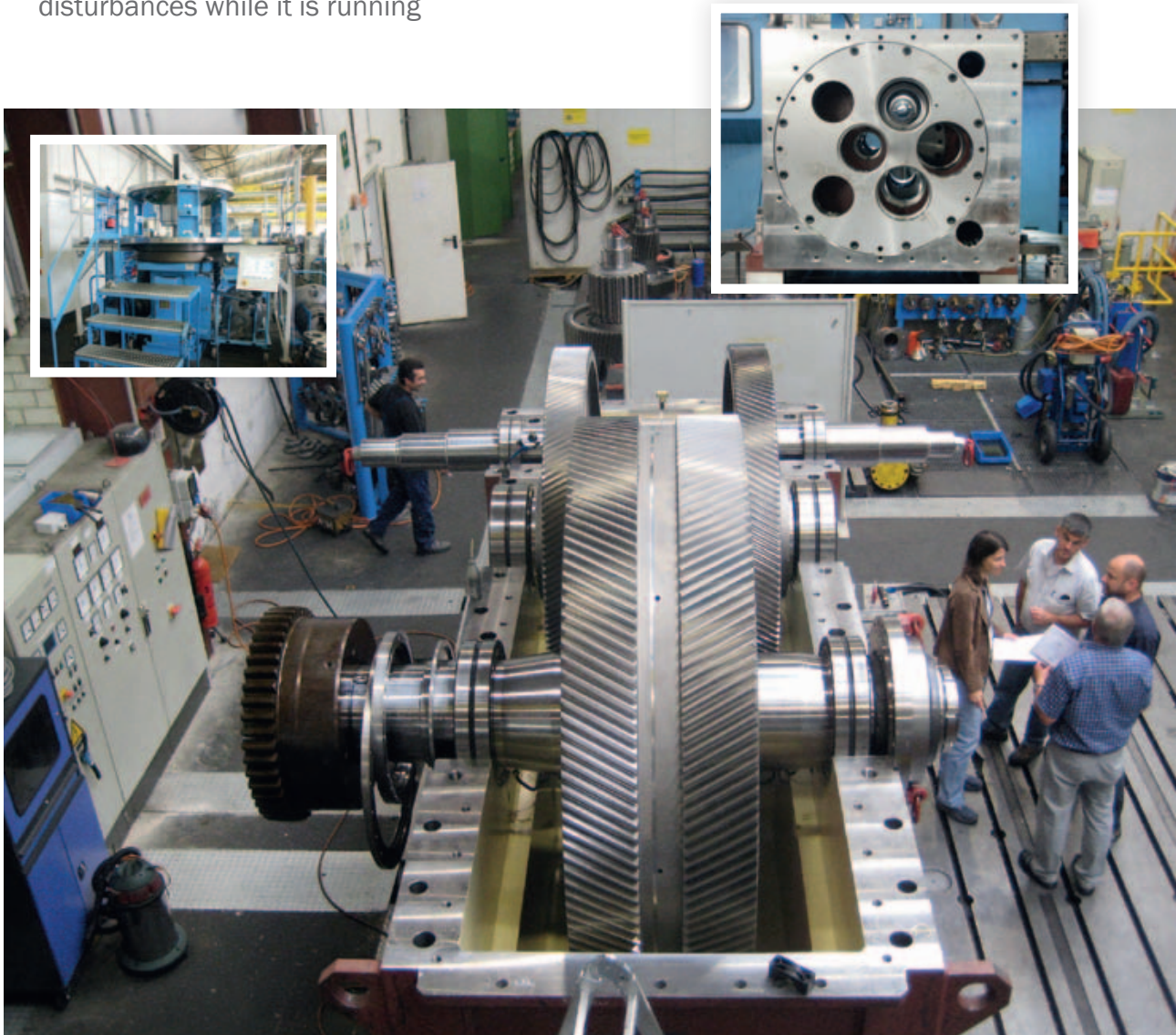



**KUMERA**  
CORPORATION

## Kumera Power Transmission Group and Marine Division



### **KUMERA DRIVES OY**

Kumerankatu 2  
FI-11100 Riihimäki  
FINLAND  
Tel: +358 20 755 4200  
E-mail: drives@kumera.com



### **KUMERA (CHINA) CO, LTD.**

168 Meifeng Road  
Kunshan 215300, Jiangsu  
CHINA  
Tel: +86 512 503 61701  
E-mail: kumerachina@kumera.com



### **KUMERA GETRIEBE GMBH**

Bonner Straße 38  
D-53842 Troisdorf  
GERMANY  
Tel: +49 2241 988-0  
Email: kumera.getriebe@kumera.com



### **KUMERA AS**

P.O. Box 2043  
N-3202 Sandefjord  
NORWAY  
Tel: +47 33 48 54 54  
E-mail: sales@kumera.no



### **KUMERA ANTRIEBSTECHNIK GMBH**

Raiffeisenstrasse 38-40  
A-8010 Graz  
AUSTRIA  
Tel: +43 316 471 524-0  
E-mail: kumera.graz@kumera.com



### **HELSETH AS**

Baklivegen 11-13  
N-6450 Hjelset  
NORWAY  
Tel: +47 71 202 900  
Email: helseth@helseth.no

## Kumera Technology Division & Foundry



**KUMERA TECHNOLOGY CENTER**  
RIIHIMÄKI, FINLAND



**KUMERA MACHINERY OY**  
AKAA, FINLAND



**PEIRON OY STEEL FOUNDRY**  
KOKEMÄKI, FINLAND

  
**KUMERA**  
GETRIEBE

### **KUMERA GETRIEBE GMBH**

Bonner Straße 38  
D-53842 Troisdorf  
GERMANY  
Tel: +49 2241 988-0  
Fax: +49 2241 988-200  
E-mail: kumera.getriebe@kumera.com